

Monolithic Integrated Feature Phone Circuit

Description

The μ c controlled telephone circuit U4092B is a linear integrated circuit for use in feature phones, answering machines and fax machines. It contains the speech circuit, tone ringer interface with dc/dc converter, sidetone equivalent and ear protection rectifiers. The circuit is line powered and contains all components necessary for amplification of signals and adaptation to the line.

An integrated voice switch with loudspeaker amplifier allows loudhearing or handsfree operation. With an anti-feedback function, acoustical feedback during loudhearing can be reduced significantly. The generated supply voltage is suitable for a wide range of peripheral circuits.

Features

- DC characteristic adjustable
- Transmit and receive gain adjustable
- Symmetrical input of microphone amplifier
- Anti-clipping in transmit direction
- Automatic line loss compensation
- Built-in ear protection
- DTMF and MUTE input
- Adjustable sidetone suppression independent of sending and receiving amplification
- Integrated amplifier for loudhearing operation
- Anti-clipping for loudspeaker amplifier
- Improved acoustical feedback suppression
- Power down
- Voice switch
- Tone ringer interface with dc/dc converter
- Zero crossing detection
- Common speaker for loudhearing and tone ringer
- Supply voltages for all functional blocks of a subscriber set
- Integrated transistor for short circuiting the line voltage
- Answering machine interface
- Operation possible from 10 mA line currents

Applications

Feature phone, answering machine, fax machine, speaker phone

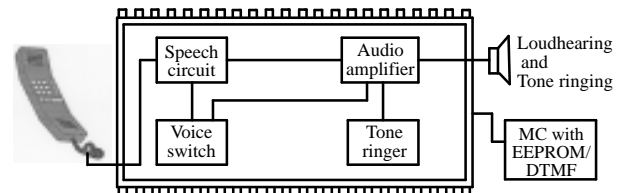

94 8741

U4092

Block diagram

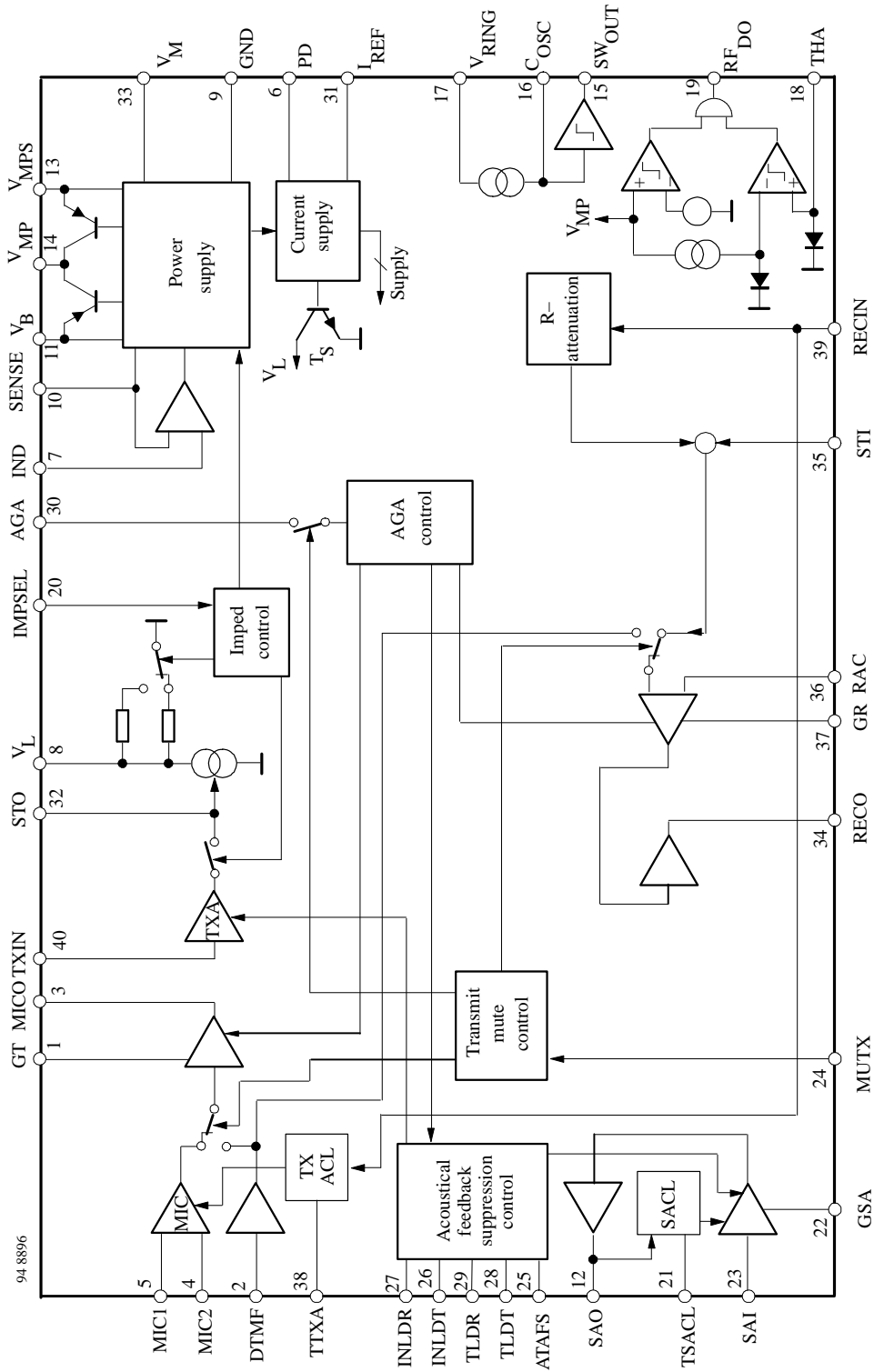

Figure 1

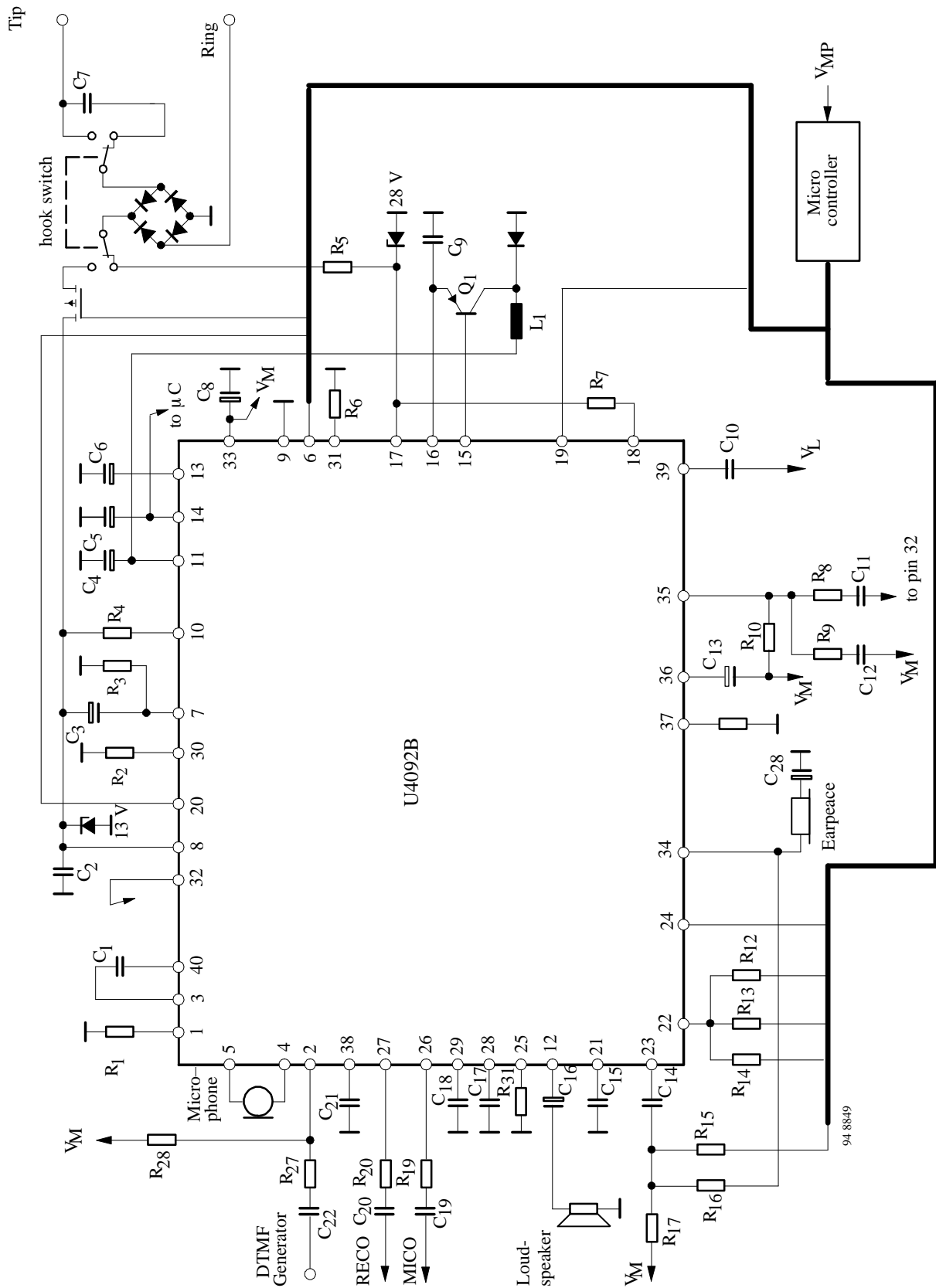

Figure 2 Application circuit for loudhearing

U4092

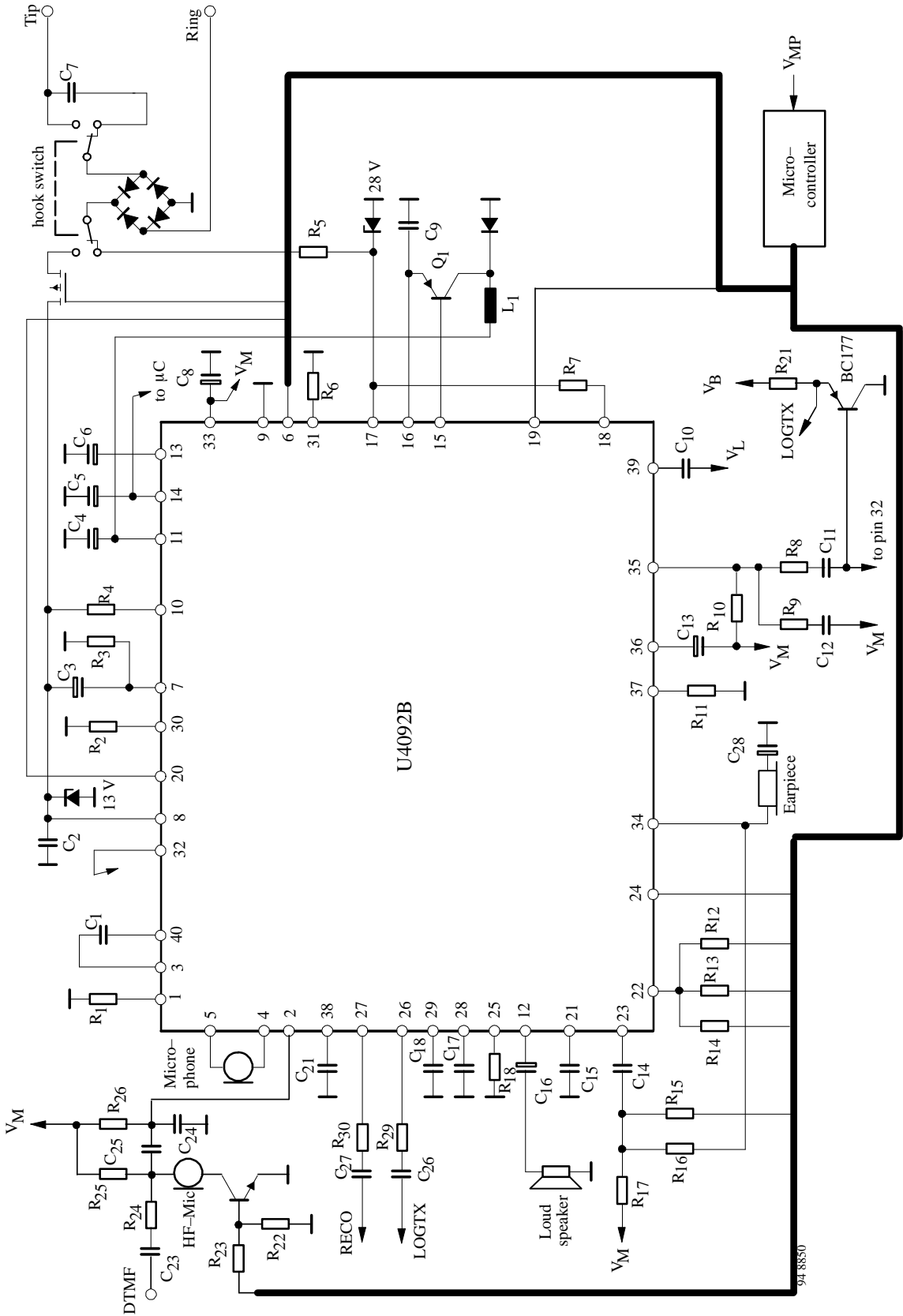

Figure 3 Application for handsfree operation

Typical value of external components

C ₁	100 nF
C ₂	4.7 nF
C ₃	10 µF
C ₄	220 µF
C ₅	47 µF
C ₆	470 µF
C ₇	820 nF
C ₈	100 µF
C ₉	100 nF
C ₁₀	150 nF
C ₁₁	68 nF
C ₁₂	33 nF
C ₁₃	10 µF
C ₁₄	100 nF
C ₁₅	1 µF
C ₁₆	47 µF
C ₁₇	10 µF
C ₁₈	10 µF
C ₁₉	68 nF
C ₂₀	68 nF
C ₂₁	1 µF
C ₂₂	100 nF
C ₂₃	6.8 nF
C ₂₄	10 nF
C ₂₅	100 nF
C ₂₆	470 nF
C ₂₇	33 nF
C ₂₈	10 µF
L ₁	2.2 mH
R ₁	27 kΩ

R ₂	20 kΩ
R ₃	> 68 kΩ
R ₄	10 Ω
R ₅	1.5 kΩ
R ₆	62 kΩ
R ₇	680 kΩ
R ₈	22 kΩ
R ₉	330 Ω
R ₁₀	3 kΩ
R ₁₁	62 kΩ
R ₁₂	30 kΩ
R ₁₃	62 kΩ
R ₁₄	120 kΩ
R ₁₅	47 kΩ
R ₁₆	1 kΩ
R ₁₇	1.2 Ω
R ₁₈	30 kΩ
R ₁₉	6.8 kΩ
R ₂₀	6.8 kΩ
R ₂₁	15 kΩ
R ₂₂	330 kΩ
R ₂₃	220 kΩ
R ₂₄	68 kΩ
R ₂₅	2 kΩ
R ₂₆	3.3 kΩ
R ₂₇	18 kΩ
R ₂₈	2 kΩ
R ₂₉	1 kΩ
R ₃₀	12 kΩ
R ₃₁	56 kΩ

U4092

Pin description

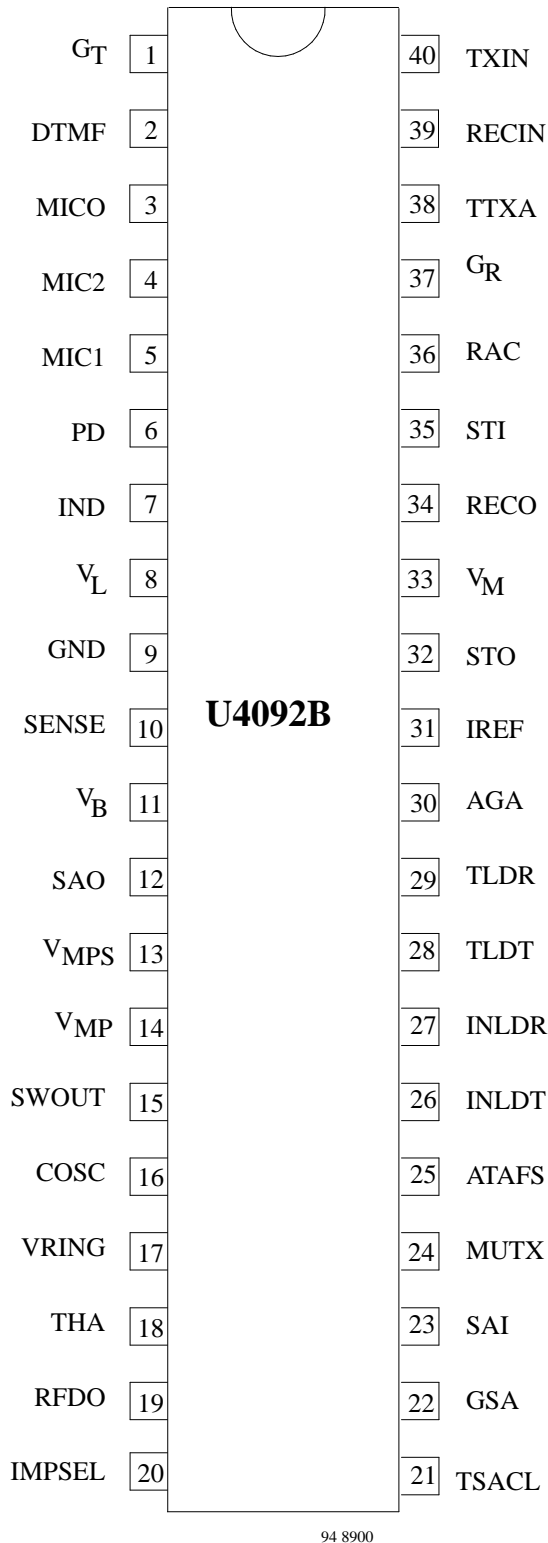

Pin	Symbol	Function
1	G _T	A resistor from this pin to GND sets the amplification of microphone and DTMF signals; the input amplifier can be muted by applying VMP to G _T .
2	DTMF	Input for DTMF signals. Also used for the answering machine and handsfree input.
3	MICO	Output of microphone preamplifier.
4	MIC 2	Non-inverting input of microphone amplifier.
5	MIC 1	Inverting input of microphone amplifier.
6	PD	Active high input for reducing the current consumption of the circuit. Simultaneously V _L is shorted by an internal switch.
7	IND	The internal equivalent inductance of the circuit is proportional to the value of the capacitor at this pin. A resistor connected to ground may be used to reduce the dc line voltage.
8	V _L	Line voltage
9	GND	Reference point for dc- and ac-output signals.
10	SENSE	A small resistor (fixed) connected from this pin to V _L sets the slope of the dc characteristic and also effects the line length equalization characteristics and the line current at which the loudspeaker amplifier is switched on.
11	V _B	Unregulated supply voltage for peripheral circuits (voice switch); limited to typically 7 V.
12	SAO	Output of loudspeaker amplifier.
13	V _{MPS}	Unregulated supply voltage for μP, limited to 6.3 V.
14	V _{MP}	Regulated supply voltage 3.3 V for peripheral circuits (especially microprocessors). The maximum output current is 2 mA.
15	SWOUT	Output for driving external switching transistor
16	COSC	40 kHz oscillator for ringing power converter

Pin	Symbol	Function
17	VRING	Input for ringing signal
18	THA	Threshold adjustment for ringing frequency detector
19	RFDO	Output of ringing frequency detector
20	IMP-SEL	Control input for selection of line impedance 1. 600 Ω 2. 900 Ω 3. Mute of second transmit stage (TXA); also used for indication of external supply (answering machine); last chosen impedance is stored.
21	TSACL	Time constant of anticlipping of speaker amplifier
22	GSA	Current input for setting the gain of the speaker amplifier. Adjustment characteristic is logarithmical. For $R_{GSA} > 2 \text{ M}\Omega$, the speaker amplifier is switched off.
23	SA I	Speaker amplifier input (for loudspeaker, tone ringer and handsfree use)
24	MUTX	Three state input of transmit mute: 1) Speech condition; inputs MIC1 / MIC2 active 2) DTMF condition; input DTMF active. A part of the input signal is passed to the receiving amplifier as a confidence signal during dialing. 3) Input DTMF used for answering machine and handsfree use; receive branch not affected.
25	ATAFS	Attenuation of acoustical feedback suppression. Maximum attenuation of AFS circuit is set by a resistor at this pin. Without the resistor, AFS is switched off.
26	INLDT	Input of transmit level detector
27	INLDR	Input of receive level detector

Pin	Symbol	Function
29	TLDT	Time constant of transmit level detector
29	TLDR	Time constant of receive level detector
30	AGA	Automatic gain adjustment with line current. A resistor connected from this pin to GND sets the starting point. Max. gain change is 6 dB.
31	IREF	Internal reference current generation; $R_{REF} = 62 \text{ k}\Omega$; $I_{REF} = 20 \mu\text{A}$
32	STO	Side tone reduction output. Output resistance is approximately 300 Ω . Maximum load impedance is 10 k Ω .
33	V_M	Reference node for microphone-earphone and loudspeaker amplifier. Supply for electret microphone ($I_M \leq 300 \mu\text{A}$).
34	RECO	Output of receiving amplifier
35	STI	Input for side tone network
36	RAC	Input of receiving amplifier for ac coupling in feedback path
37	G_R	A resistor connected from this pin to GND sets the receiving amplification of the circuit; amplifier RA1 can be muted by applying VMP to G_R
38	TTXA	Time constant of anticlipping in transmit path
39	RECIN	Input of receiving path; input impedance is typically 80 k Ω
40	TXIN	Input of intermediate transmit stage, input resistance is typically 20 k Ω

U4092

DC line interface and supply voltage generation

The DC line interface consists of an electronic inductance and a dual port output stage, which charges the capacitors at V_{MPS} and V_B . The value of the equivalent inductance is given by

$$L = R_{SENSE} \cdot C_{IND} \cdot (R_{DC} \cdot R_{30}) / (R_{DC} + R_{30})$$

In order to improve the supply during worst case operating

conditions two PNP current sources – I_{BOPT} and I_{MPSOPT} – hand an extra amount of current to the supply voltages, when the NPNs in parallel are unable to conduct current.

A flowchart for the control of the current sources (figure 5) shows, how a priority for supply V_{MPS} is achieved.

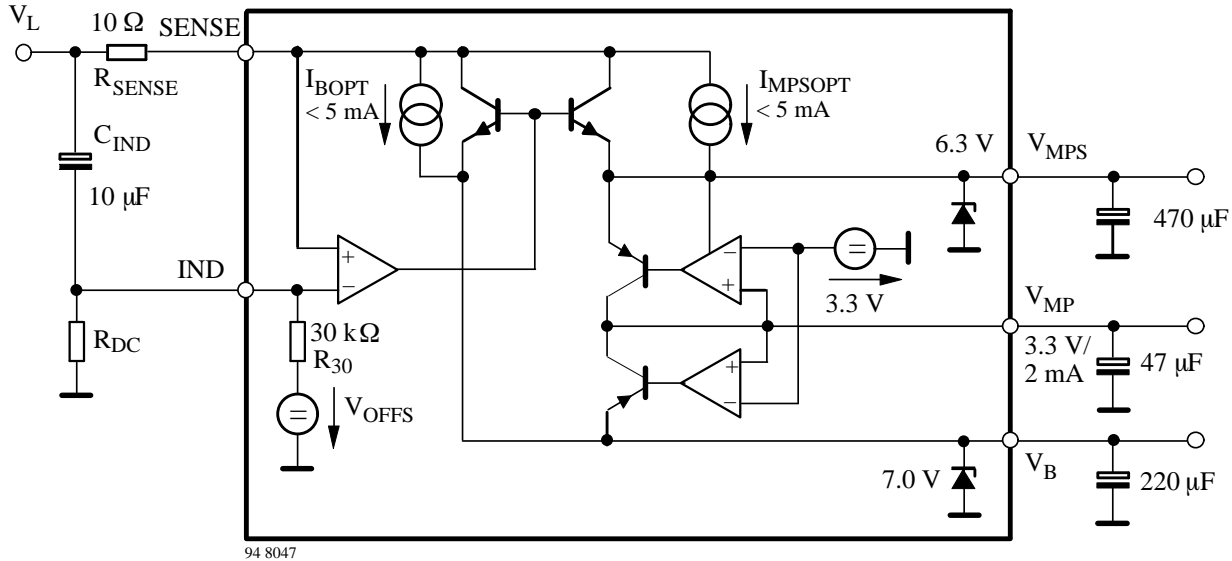

94 8047

Figure 4 DC line interface with electronic inductance and generation of a regulated and an unregulated supply

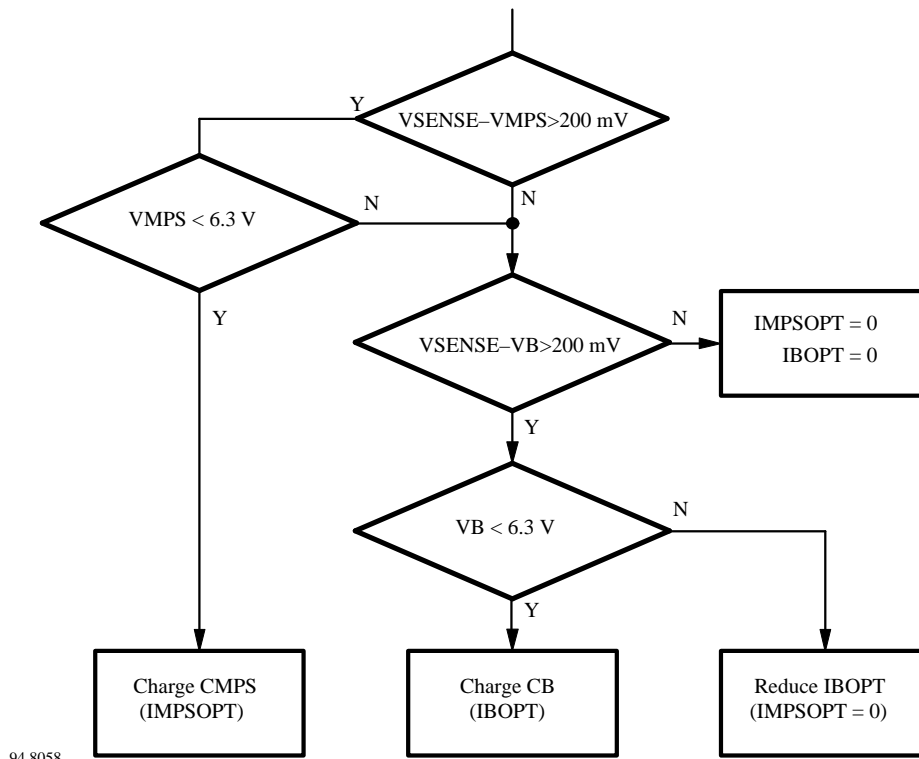

94 8058

Figure 5 Supply capacitors CMPS and CB are charged with priority on CMPS

The U4092B contains two identical series regulators, which provide a supply voltage V_{MP} of 3.3 V at 2 mA suitable for a microprocessor. In speech mode both regulators are active, because V_{MPS} and V_B are charged simultaneously by the DC-line interface. The capacitor at V_{MPS} is used to provide the microcomputer with sufficient

power during long line interruptions. Thus long flash pulses can be bridged or a LCD display can be turned on for more than 2 seconds after going on hook. When the system is in ringing mode, V_B is charged by the on chip ringing power converter. In this mode only one regulator is used to supply V_{MPS} .

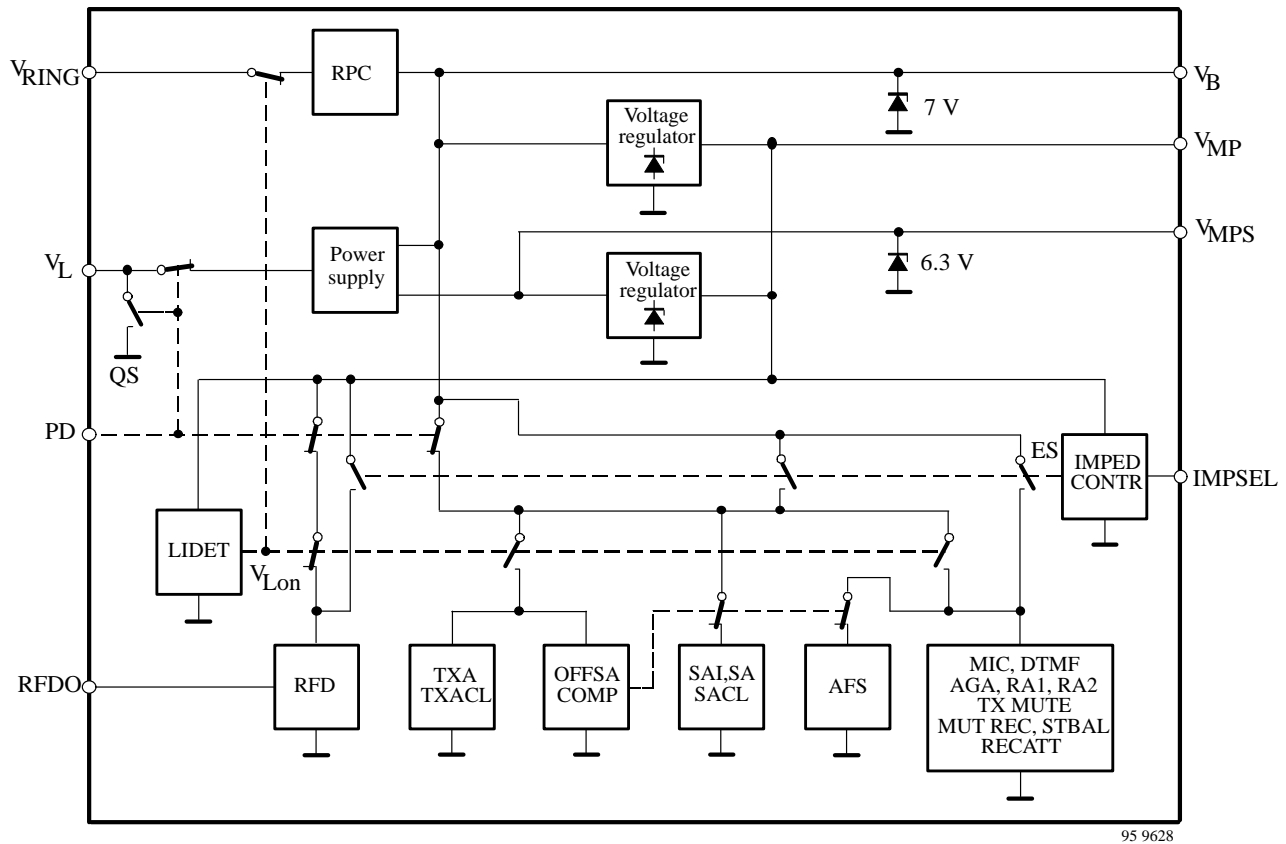

Figure 6 Supply of functional blocks is controlled by input voltages V_L , V_B , V_{ring} and by logic inputs PD and IMPSEL

There are four major supply states:

1. Speech condition
2. Power down (pulse dialing)
3. Ringing
4. External supply
5. In speech condition the system is supplied by the line current. If the LIDET-block detects a line voltage above the fixed threshold (1.9 V), the internal signal VLON is activated, thus switching off RFD and RPC and switching on all other blocks of the chip.

For line voltages below 1.9 V the switches remain in their quiescent state as shown the diagram.

OFFSACOMP disables the group listening feature (SAI, SA, SACL, AFS) below line currents of approximately 10 mA.

6. When the chip is put into Power-down mode (PD = high), e.g. during pulse dialing, the internal switch QS shorts the line and all amplifiers are switched off. In this condition LIDET, voltage regulators and IMPED CONTR are the only active blocks.

7. During ringing the supply for the system is fed into V_B via the ringing power converter (RPC). The only functional amplifiers are found in the speaker amplifier section (SAI, SA, SACL).
8. In an answering machine the chip is powered by an external supply via pin V_B . This application demands a possibility to activate all amplifiers (except the transmit line interface TXA). Selecting IMPSEL = high impedance activates all switches at the ES line.

Acoustic feedback suppression

Acoustical feedback from the loudspeaker to the handset microphone may cause instability in the system. The U4092B offers a very efficient feedback suppression circuit, which uses a modified voice switch topology. figure 8 shows the basic system configuration.

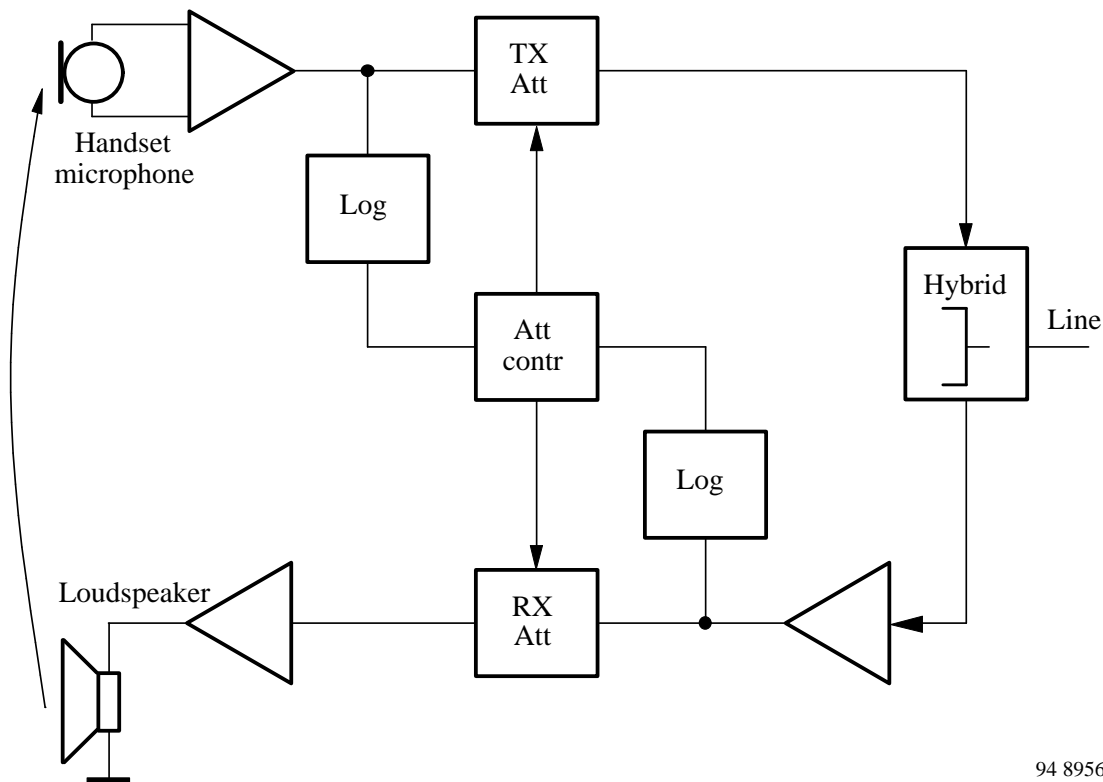

94 8956

Figure 8 Basic voice switch system

Two attenuators (TX ATT and RX ATT) reduce the critical loop gain by introducing an externally adjustable amount of loss either in the transmit or in the receive path. The sliding control in block ATT CONTR determines, whether the TX or the RX signal has to be attenuated. The overall loop gain remains constant under all operating conditions. Selection of the active channel is made by comparison of

the logarithmically compressed TX- and RX- envelope curve.

The system configuration for group listening, which is realized in the U4092B, is illustrated in figure 9. TXA and SAI represent the two attenuators, whereas the logarithmic envelope detectors are shown in a simplified way (operational amplifiers with two diodes).

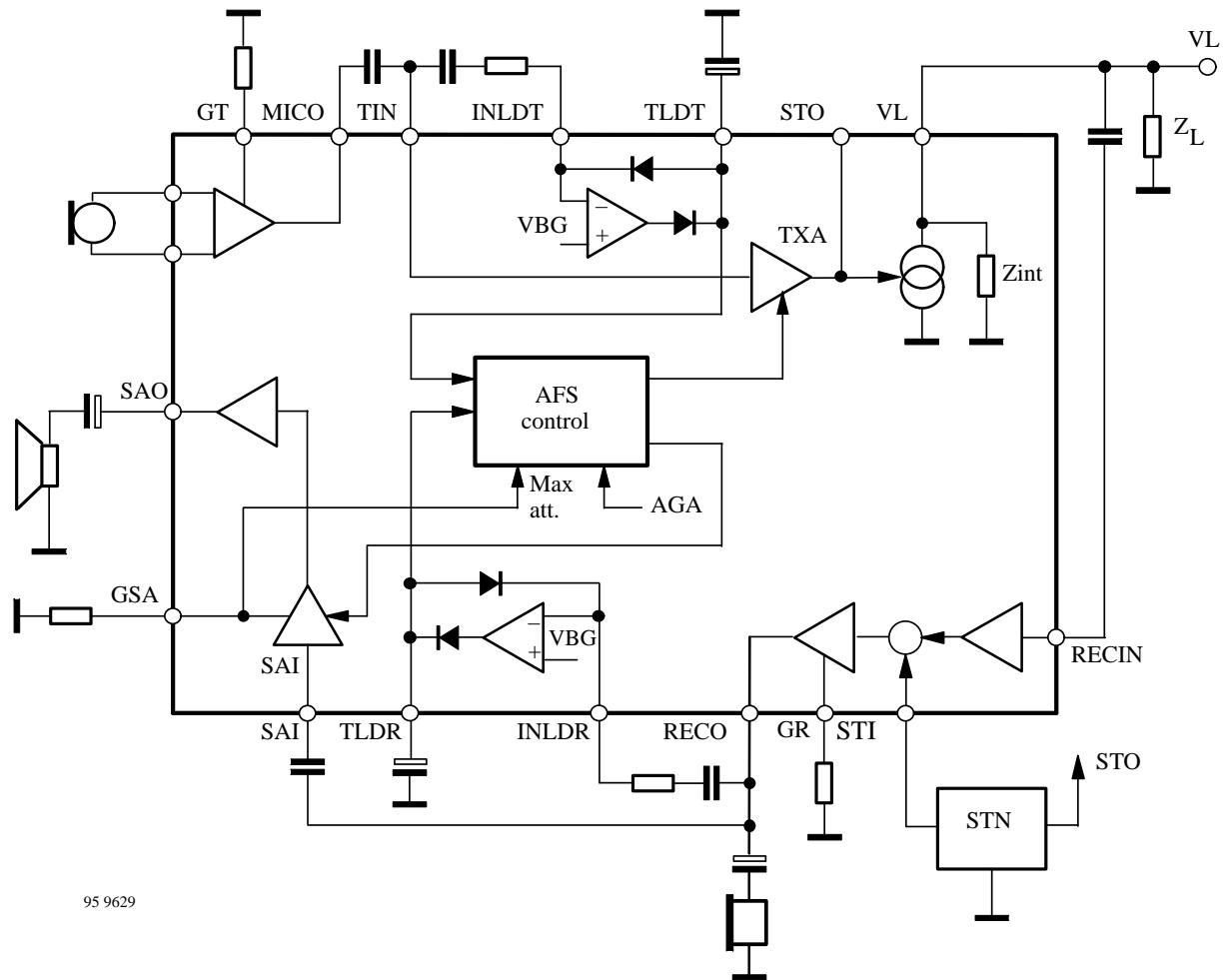

95 9629

Figure 9 Integration of acoustic feedback suppression circuit into the speech circuit environment

A detailed diagram of the AFS (acoustic feedback suppression) is given in figure 10. Receive and Transmit signals are first processed by logarithmic rectifiers in order

to produce the envelopes of the speech at TLDT and RLDT. After amplification a decision is made by the differential pair, which direction should be transmitted.

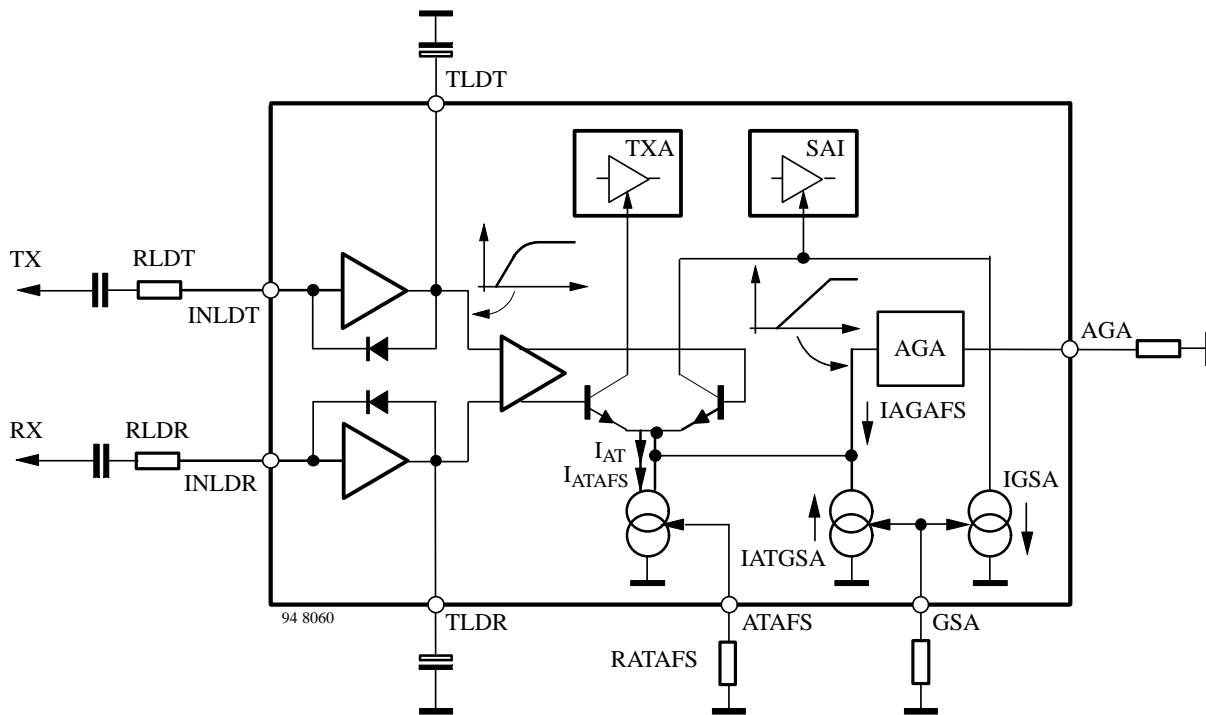

Figure 10 Acoustic feedback suppression by alternative control of transmit- and speaker amplifier gain

The attenuation of the controlled amplifiers TXA and SAI is determined by the emitter current I_{AT} , which is comprised of three parts:

I_{ATAFS} sets maximum attenuation

I_{ATGSA} decreases the attenuation, when speaker amplifier gain is reduced

I_{AGAFS} decreases the attenuation according to the loop gain reduction caused by the AGA-function

$$I_{AT} = I_{ATAFS} - I_{ATGSA} - I_{AGAFS}$$

$$\Delta G = I_{AT} * 0.67 \text{ dB}/\mu\text{A}$$

Figure 11 illustrates the principal relationship between speaker amplifier gain (GSA) and attenuation of AFS

(ATAFS). Both parameters can be adjusted independently, but the internal coupling between them has to be considered. Maximum usable value of GSA is 36 dB. The shape of the characteristic is moved in the x-direction by adjusting resistor RATAFS, thus changing $ATAFS_m$. The actual value of attenuation ($ATAFS_a$), however, can be determined by reading the value which belongs to the actual gain GSA_a . If the speaker amplifier gain is reduced, the attenuation of AFS is automatically reduced by the same amount, in order to achieve a constant loop gain. Zero attenuation is set for speaker gains $GSA \leq GSA_0 = 36 \text{ dB} - ATAFS_m$.

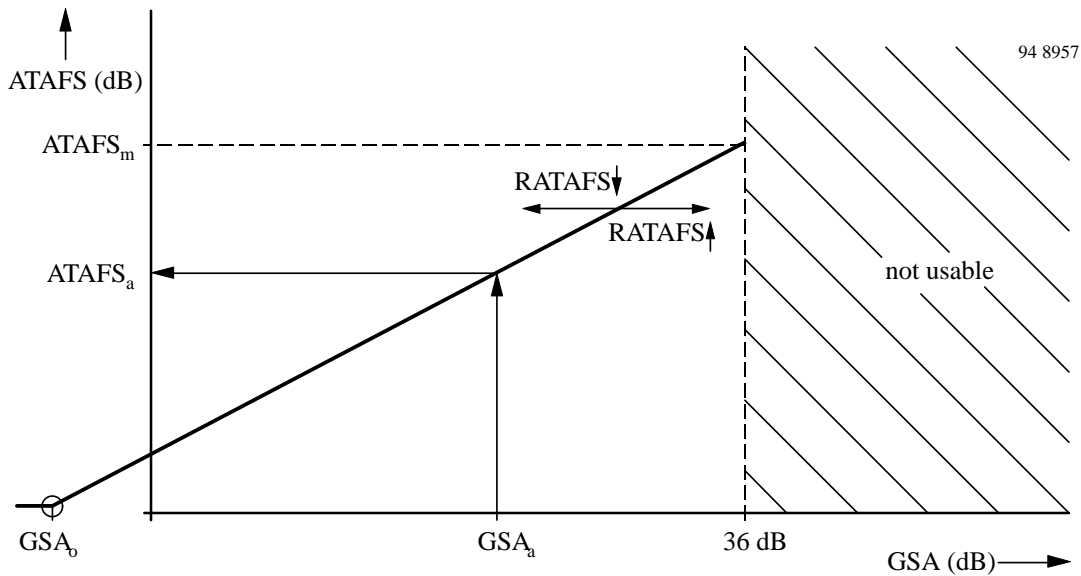

Figure 11 Reducing speaker amplifier gain results in an equal reduction of AFS attenuation

Ringling power converter (RPC)

RPC transforms the input power at VRING (high voltage/ low current) into an equivalent output power at V_B (low voltage/ high current), which is capable of driving the low ohmic loudspeaker. Input impedance at VRING is fixed at $5\text{ k}\Omega$ and the efficiency of the step down converter is approx. 65%.

Ringling frequency detector (RFD)

The U4092B offers an output signal for the microcontroller, which is a digital representation of the double ringing frequency. It is generated by a current comparator with hysteresis. Input voltage VRING is transformed into a current via RTHA. Thresholds are $8\text{ }\mu\text{A}$ and $24\text{ }\mu\text{A}$. RFDO and VRING are in phase. A second comparator with hysteresis is used to enable the output RFDO, as long as the supply voltage for the microprocessor VMP is above 2.4 V (2.9 V).

Absolute maximum ratings

Parameters	Symbol	Value	Unit
Line current	I_L	140	mA
DC line voltage	V_L	12	V
Maximum input current Pin 17	I_{RING}	15	mA
Junction temperature	T_j	125	°C
Ambient temperature	T_{amb}	-25 to +75	°C
Storage temperature	T_{stg}	-55 to +150	°C
Total power dissipation, $T_{amb} = 60^\circ\text{C}$	P_{tot}	1	W

Thermal resistance

Parameters	Symbol	Value	Unit
Junction ambient SDIP 40	R_{thJA}	50	K/W

Electrical characteristics

$f = 1 \text{ kHz}$, $0 \text{ dBm} = 775 \text{ mV}_{rms}$, $I_M = 0.3 \text{ mA}$, $I_{MP} = 2 \text{ mA}$, $RDC = 130 \text{ k}\Omega$, $T_{amb} = 25^\circ\text{C}$, $RGSA = 560 \text{ k}\Omega$, $Z_{ear} = 68 \text{ nF} + 100 \text{ }\Omega$, $Z_M = 68 \text{ nF}$, pin 31 open, $V_{IMPSEL} = GND$, $V_{MUTX} = GND$, unless otherwise specified.

Parameters	Test conditions / Pin	Symbol	Min.	Typ.	Max.	Unit	Figure
DC characteristics							
DC voltage drop over circuit	$I_L = 2 \text{ mA}$ $I_L = 14 \text{ mA}$ $I_L = 60 \text{ mA}$ $I_L = 100 \text{ mA}$	V_L	4.6	2.4 5.0 7.5 9.4	5.4 10.0	V	22
Transmission amplifier, $I_L = 14 \text{ mA}$, $V_{MIC} = 2 \text{ mV}$, $RGT = 27 \text{ k}\Omega$, unless otherwise specified							
Adjustment range of transmit gain		G_T	40	45	50	dB	24
Transmitting amplification	$RGT = 12 \text{ k}\Omega$ $RGT = 27 \text{ k}\Omega$	G_T	47 39.8	48	49 41.8	dB	24
Frequency response	$I_L \geq 14 \text{ mA}$, $f = 300 \text{ to } 3400 \text{ Hz}$	ΔG_T			± 0.5	dB	24
Gain change with current	Pin 31 open $I_L = 14 \text{ to } 100 \text{ mA}$	ΔG_T			± 0.5	dB	24
Gain deviation	$T_{amb} = -10 \text{ to } +60^\circ\text{C}$	ΔG_T			± 0.5	dB	24
CMRR of microphone amplifier		CMRR	60	80		dB	24
Input resistance of MIC amplifier	$RGT = 12 \text{ k}\Omega$ $RGT = 27 \text{ k}\Omega$	R_i	45	50 75	110	$\text{k}\Omega$	24
Distortion at line	$I_L > 14 \text{ mA}$ $V_L = 700 \text{ mV}_{rms}$	d_t			2	%	24
Maximum output voltage	$I_L > 19 \text{ mA}$ $d < 5\%$ $V_{mic} = 25 \text{ mV}$ $CTXA = 1 \text{ }\mu\text{F}$	V_{Lmax}	1.8	3	4.2	dBm	24
Noise at line psophometrically weighted	$I_L > 14 \text{ mA}$ $G_T = 48 \text{ dB}$	no		-80	-72	dBmp	24
Anti-clipping attack time release time	$CTXA = 1 \text{ }\mu\text{F}$ each 3 dB overdrive			0.5 9		ms	24

Parameters	Test conditions / Pin	Symbol	Min.	Typ.	Max.	Unit	Figure
Gain at low operating current	$I_L = 10 \text{ mA}$ $I_{MP} = 1 \text{ mA}$ $RDC = 68 \text{ k}\Omega$ $V_{mic} = 1 \text{ mV}$ $I_M = 300 \mu\text{A}$	G_T	40		42.5	dB	24
Distortion at low operating current	$I_L = 10 \text{ mA}$ $I_M = 300 \mu\text{A}$ $I_{MP} = 1 \text{ mA}$ $RDC = 68 \text{ k}\Omega$ $V_{mic} = 10 \text{ mV}$	d_t			5	%	24
Line loss compensation	$I_L = 100 \text{ mA}$, $RAGA = 20 \text{ k}\Omega$	ΔG_{TI}	-6.4	-5.8	-5.2	dB	24
Mute suppression a) MIC muted (microphone preamplifier)	$I_L \geq 14 \text{ mA}$ Mutx = open	G_{TM}	60	80		dB	24
b) TXA muted (second stage)	IMPSEL = open	G_{TTX}	60			dB	24
Receiving amplifier, $I_L = 14 \text{ mA}$, $RGR = 62 \text{ k}$, unless otherwise specified, $V_{GEN} = 300 \text{ mV}$							
Adjustment range of receiving gain	$I_L \geq 14 \text{ mA}$, single ended	G_R	-8		+2	dB	23
Receiving amplification	$RGR = 62 \text{ k}\Omega$ $RGR = 22 \text{ k}\Omega$	G_R	-7.75	-7 1.5	-6.25	dB	23
Amplification of DTMF signal from DTMF IN to RECO	$I_L \geq 14 \text{ mA}$ $V_{MUTX} = V_{MP}$	G_{RM}	1	4	7	dB	23
Frequency response	$I_L > 14 \text{ mA}$, $f = 300 \text{ to } 3400 \text{ Hz}$	ΔG_{RF}			± 0.5	dB	23
Gain change with current	$I_L = 14 \text{ to } 100 \text{ mA}$	ΔG_R			± 0.5	dB	23
Gain deviation	$T_{amb} = -10 \text{ to } +60^\circ\text{C}$	ΔG_R			± 0.5	dB	23
Ear protection	$I_L \geq 14 \text{ mA}$ $V_{GEN} = 11 \text{ V}_{rms}$	EP			1.1	V_{rms}	23
MUTE suppression DTMF operation	$I_L \geq 14 \text{ mA}$ $V_{MUTX} = V_{MP}$	ΔG_R	60			dB	23
Output voltage $d \leq 2\%$	$I_L = 14 \text{ mA}$ $Z_{ear} = 68 \text{ nF}$		0.5			V_{rms}	23
Maximum output current $d \leq 2\%$	$Z_{ear} = 100 \Omega$		4			mA (peak)	23
Receiving noise psophometrically weighed	$Z_{ear} = 68 \text{ nF} + 100 \Omega$ $I_L \geq 14 \text{ mA}$	ni		-80	-77	dBmp	23
Output resistance	Output against GND	R_o			10	Ω	23
Line loss compensation	$RAGA = 20 \text{ k}\Omega$, $I_L = 100 \text{ mA}$	ΔG_{RI}	-7.0	-6.0	-5.0	dB	23

Parameters	Test conditions / Pin	Symbol	Min.	Typ.	Max.	Unit	Figure
Gain at low operating current	$I_L = 10 \text{ mA}$ $I_{MP} = 1 \text{ mA}$ $I_M = 300 \mu\text{A}$ $V_{GEN} = 560 \text{ mV}$ $RDC = 68 \text{ k}\Omega$	G_R	-8	-7	-6	dB	23
AC impedance	$V_{IMPSEL} = \text{GND}$ $V_{IMPSEL} = V_{MP}$	Z_{imp} Z_{imp}	570 840	600 900	640 960	Ω Ω	23
Distortion at low operating current	$I_L = 10 \text{ mA}$ $I_{MP} = 1 \text{ mA}$ $V_{GEN} = 560 \text{ mV}$ $RDC = 68 \text{ k}\Omega$	dR			5	%	23
Speaker amplifier							
Minimum line current for operation	No ac signal	I_{Lmin}			15	mA	27
Input resistance	Pin 24		14		22	k Ω	27
Gain from SAI to SAO	$V_{SAI} = 3 \text{ mV}$, $I_L = 15 \text{ mA}$, $RGSA = 560 \text{ k}\Omega$ $RGSA = 20 \text{ k}\Omega$	G_{SA}	35.5	36.5 - 3	37.5	dB	27
Output power	Load resistance $R_L = 50 \Omega$, $d < 5\%$ $V_{SAI} = 20 \text{ mV}$ $I_L = 15 \text{ mA}$ $I_L = 20 \text{ mA}$	P_{SA} P_{SA}	3	7 20		mW	27
Output noise (Input SAI open) psophometrically weighted	$I_L > 15 \text{ mA}$	n_{SA}			200	μV_{psoph}	27
Gain deviation	$I_L = 15 \text{ mA}$ $T_{amb} = -10 \text{ to } +60^\circ\text{C}$	ΔG_{SA}			± 1	dB	27
Mute suppression	$I_L = 15 \text{ mA}$, $V_L = 0 \text{ dBm}$, $V_{SAI} = 4 \text{ mV}$ Pin 23 open	VSAO			-60	dBm	27
Gain change with current	$I_L = 15 \text{ to } 100 \text{ mA}$	ΔG_{SA}			± 1	dB	27
Resistor for turning off speaker amplifier	$I_L = 15 \text{ to } 100 \text{ mA}$	RG_{SA}	0.8	1.3	2	M Ω	27
Gain change with frequency	$I_L = 15 \text{ mA}$ $f = 300 \text{ to } 3400 \text{ Hz}$	ΔG_{SA}			± 0.5	dB	27
Attack time of anti-clipping	20 dB over drive	tr		5		ms	27
Release time of anti-clipping		tf		80		ms	27
DTMF-amplifier Test conditions: $I_{MP} = 2 \text{ mA}$, $I_M = 0.3 \text{ mA}$, $V_{MUTX} = V_{MP}$							
Adjustment range of DTMF gain	$I_L = 15 \text{ mA}$ Mute active	G_D	40		50	dB	25
DTMF amplification	$I_L = 15 \text{ mA}$, $V_{DTMF} = 8 \text{ mV}$ Mute active: $MUTX = V_{MP}$	G_D	40.7	41.7	42.7	dB	25
Gain deviation	$I_L = 15 \text{ mA}$ $T_{amb} = -10 \text{ to } +60^\circ\text{C}$	G_D			± 0.5	dB	25

Parameters	Test conditions / Pin	Symbol	Min.	Typ.	Max.	Unit	Figure
Input resistance	RGT = 27 k Ω RGT = 15 k Ω	R _i	60 26	180 70	300 130	k Ω	25
Distortion of DTMF signal	I _L \geq 15 mA V _L = 0 dBm	d _D			2	%	25
Gain deviation with current	I _L = 15 to 100 mA	Δ GD			\pm 0.5	dB	25
AFS acousting feedback suppression							
Adjustment range of attenuation	I _L \geq 15 mA		0		50	dB	27
Attenuation of transmit gain	I _L \geq 15 mA, I _{INLDT} = 0 μ A R _{ATAFS} = 30 k Ω I _{INLDR} = 10 μ A	Δ G _T		45		dB	27
Attenuation of speaker amplifier	I _L \geq 15 mA I _{INLDP} = 0 μ R _{ATAFS} = 30 k Ω I _{INLDR} = 10 μ	Δ G _{SA}		50		dB	27
AFS disable	I _L \geq 15 mA	V _{ATAFS}	1.5			V	27
Supply voltages, V_{mic} = 25 mV, T_{amb} = - 10 to + 60°C							
V _{MP}	I _L = 14 mA, RDC = 68 k Ω I _{MP} = 2 mA	V _{MP}	3.1	3.3	3.5	V	22
V _{MPS}	I _L = 100 mA RDC = inf., I _{MP} = 0 mA	V _{MPS}			6.7	V	22
V _M	I _L \geq 14 mA, I _M = 300 μ A RDC = 130 k Ω	V _M	1.4		3.3	V	22
V _B	I _B = + 20 mA, I _L = 0 mA	V _B		7	7.6	V	22
Ring power converter, I_{MP} = 1 mA, I_M = 0							
Maximum output power	V _{RING} = 20.6 V	P _{SA}		20		mW	26
Threshold of ring frequency detector	RFDO: low to high V _{HYST} = V _{RINGON} - V _{RING} OFF	V _{RINGON}		17.5		V	26
		V _{HYST}		11.0			
Input impedance	V _{RING} = 30 V	R _{RING}	4	5	6	k Ω	26
Input impedance in speech mode	f = 300 Hz to 3400 Hz I _L > 15 mA, V _{RING} = 20V + 1.5V _{rms}	R _{RINGSP}	150			k Ω	26
Logic-level of frequency detector	V _{RING} = 0 V, V _B = 4 V V _{RING} = 25 V	V _{RFDO}		0		V	26
		V _{MP}					
Ring detector enable	V _{RING} = 25 V, RFDO high	V _{MPON}	2.7	2.9	3.1	V	26
Ring detector disable	V _{RING} = 25 V, RFDO low	V _{MPOFF}	2.2	2.35	2.5	V	26

Parameters	Test conditions / Pin	Symbol	Min.	Typ.	Max.	Unit	Figure
PD input							
PD input current	PD active, $I_L > 14 \text{ mA}$ $V_{PD} = V_{MP}$	I_{pd}		9		μA	28
Input voltage	PD = active PD = inactive	V_{pd} V_{pd}	2		0.3	V	28
Voltage drop at V_L	$I_L = 14 \text{ mA}$, PD = active $I_L = 100 \text{ mA}$, PD = active	V_L		1.5		V	28
		V_L		1.9			
Input characteristics of IMPSEL							
Input current	$I_L \geq 14 \text{ mA}$ $V_{IMPSEL} = V_{MP}$ $V_{IMPSEL} = \text{GND}$	I_{IMPSEL} I_{IMPSEL}		18 -18		μA μA	28
Input voltage	Input high	V_{IMPSEL}	VMP-0.3V			V	28
	Input low	V_{IMPSEL}			0.3	V	28
MUTX input							
Input current	$V_{MUTX} = V_{MP}$ $V_{MUTX} = \text{GND}$	I_{MUTX} I_{MUTX}		20 -20	30 -30	μA μA	28
Input voltage	Input high	V_{MUTX}	VMP-0.3V			V	28
	Input low	V_{MUTX}			0.3	V	28

U4092B – control

	IMPSEL	MODE
0	Line-impedance = 600 Ω TXA = on ES = off	Speech
0 to Z	Line-impedance = 600 Ω TXA = off ES = on	Transmit-mute
1 to Z	Line-impedance = 900 Ω TXA = off ES = on	Transmit-mute
1	Line-impedance = 900 Ω TXA = on ES = off	Speech

	MUTX	MODE
0	MIC 1/2 transmit enabled receive enable AFS = on AGA = on TXACL = on	Speech
Z	DTMF transmit enabled receive enable AFS = on AGA = on TXACL = on	For answering machine
1	DTMF transmit enabled DTMF to receive enable AFS = off AGA = off TXACL = off	DTMF dialling

Logic-level
0 = < (0.3 V)
Z = > (1 V) < (VMP - 1 V) or (open input)
1 = > (VMP - 0.3 V)

RECATT = Receive attenuation
 STI = Input of sidetone balancing amplifier
 ES = External supply
 AFS = Acoustical feedback suppression control
 AGA = Automatic gain adjustment
 TXACL = Transmit anticlipping control

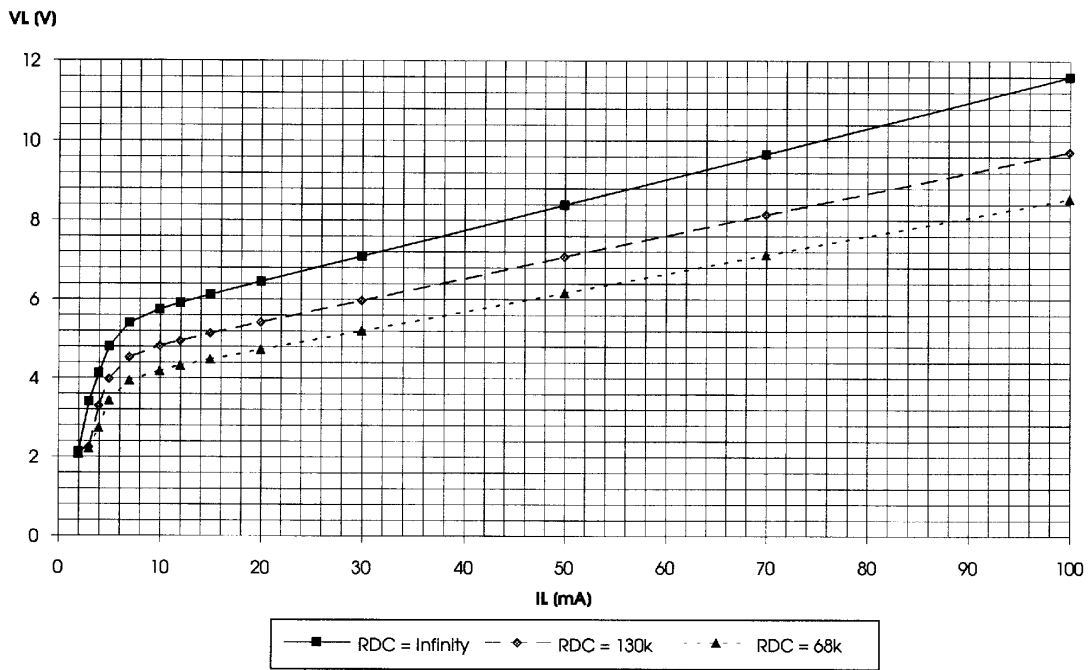

94 8856

Figure 14 Typical DC characteristic

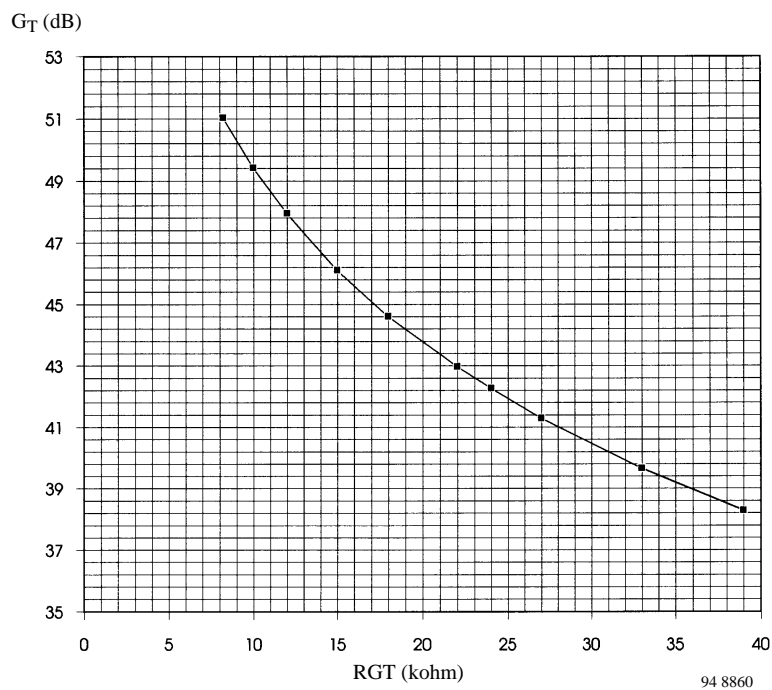

94 8860

Figure 15 Typical adjustment range of transmit gain

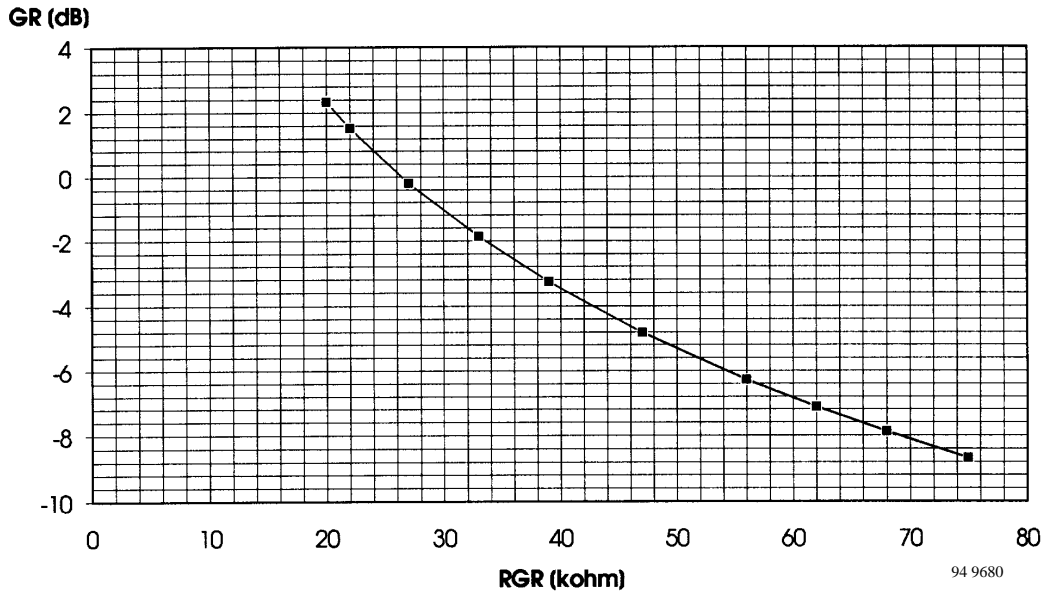

Figure 16 Typical adjustment range of receive gain

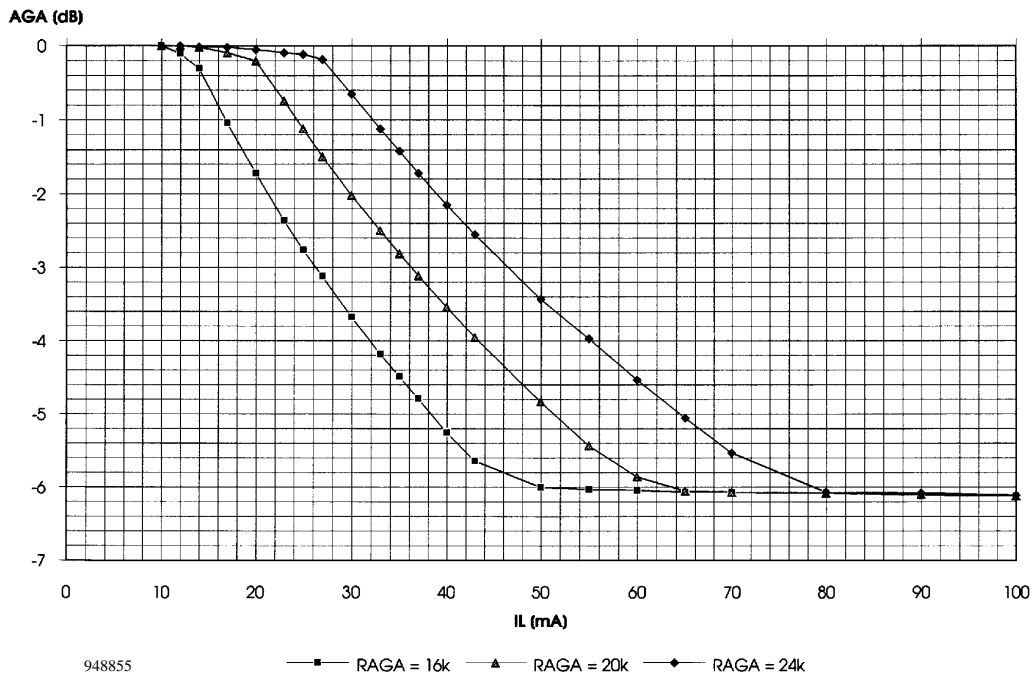

Figure 17 Typical AGA-characteristic

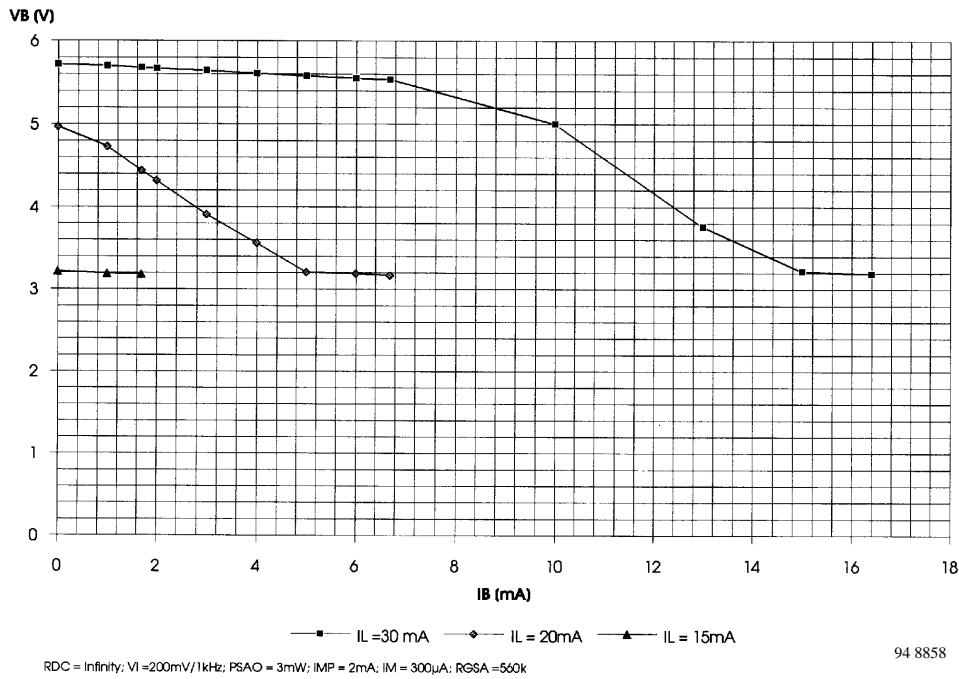

Figure 18 Typical load characteristic of V_B for a maximum (RDC = infinity) DC-characteristic and 3 mW loudspeaker output

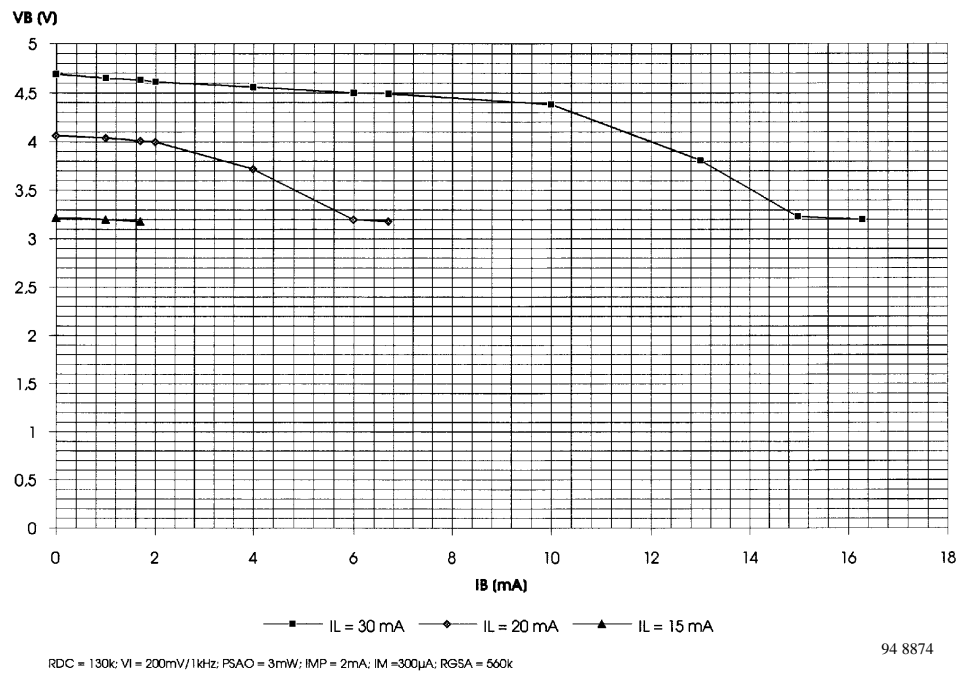

Figure 19 Typical load characteristic of V_B for a medium DC-characteristic (RDC = 130 k Ω) and 3 mW loudspeaker output

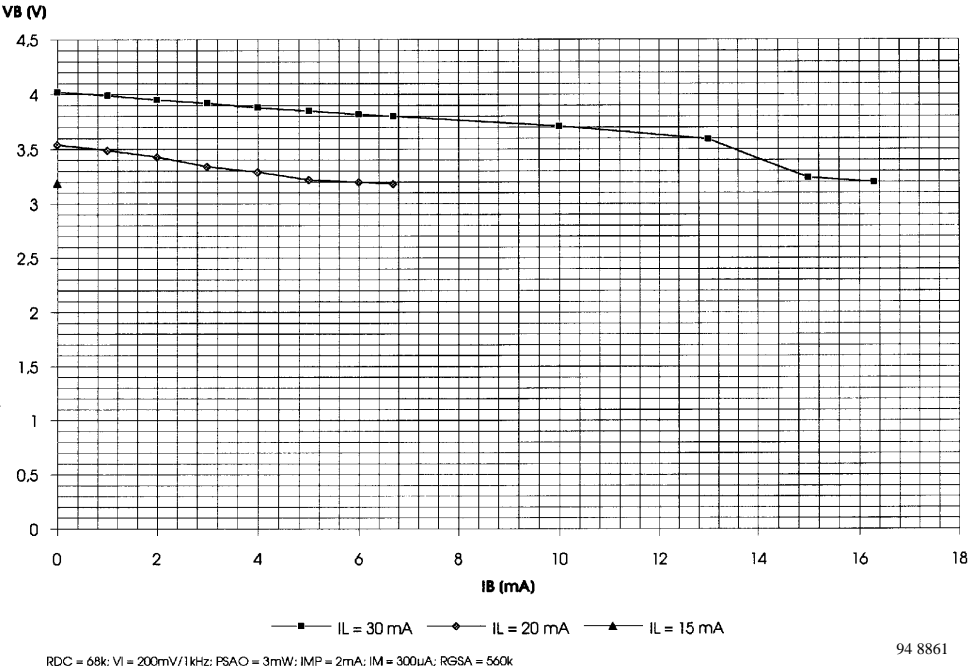

Figure 20 Typical load characteristic of V_B for a minimum DC-characteristic (RDC = 68 k Ω) and 3 mW loudspeaker output

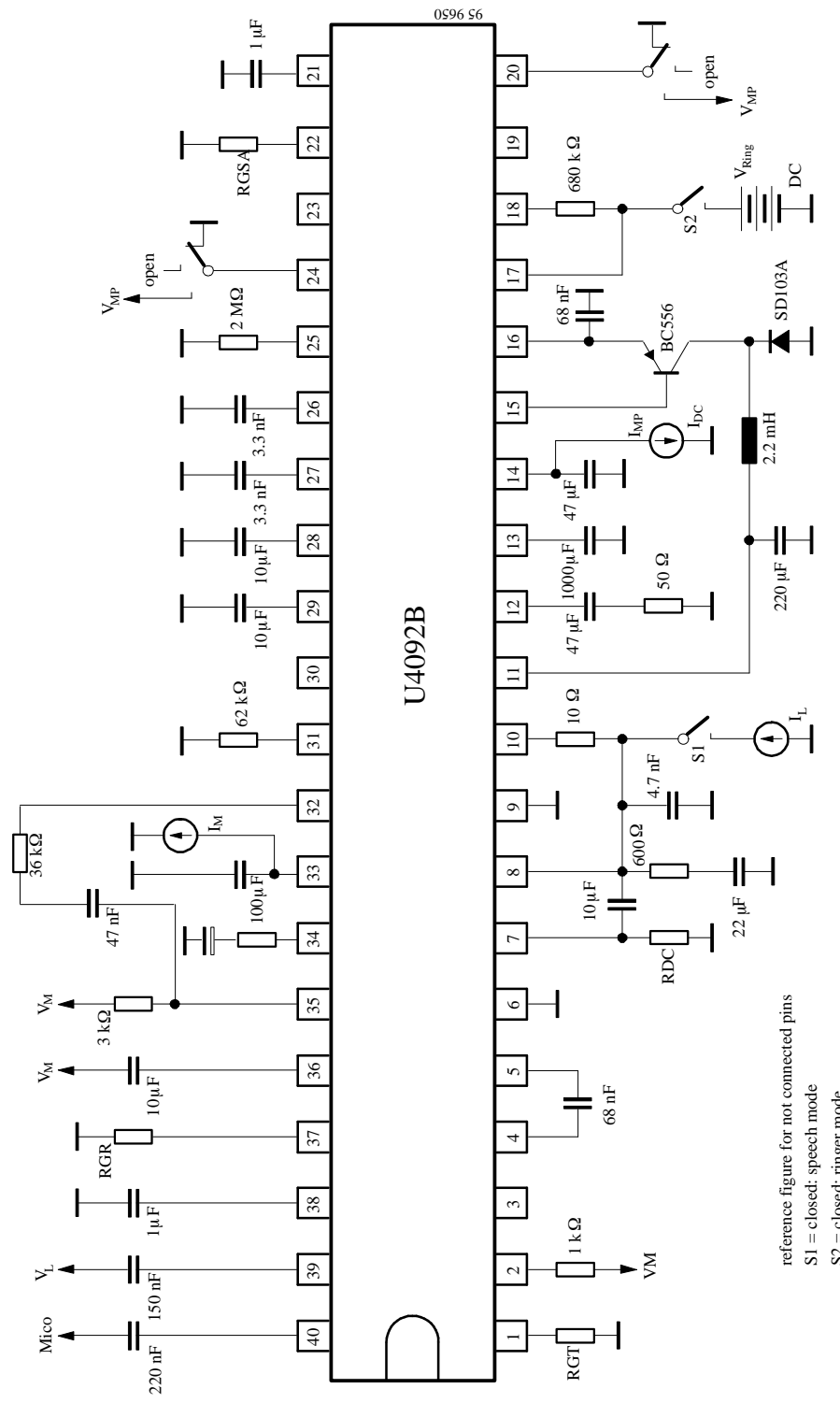
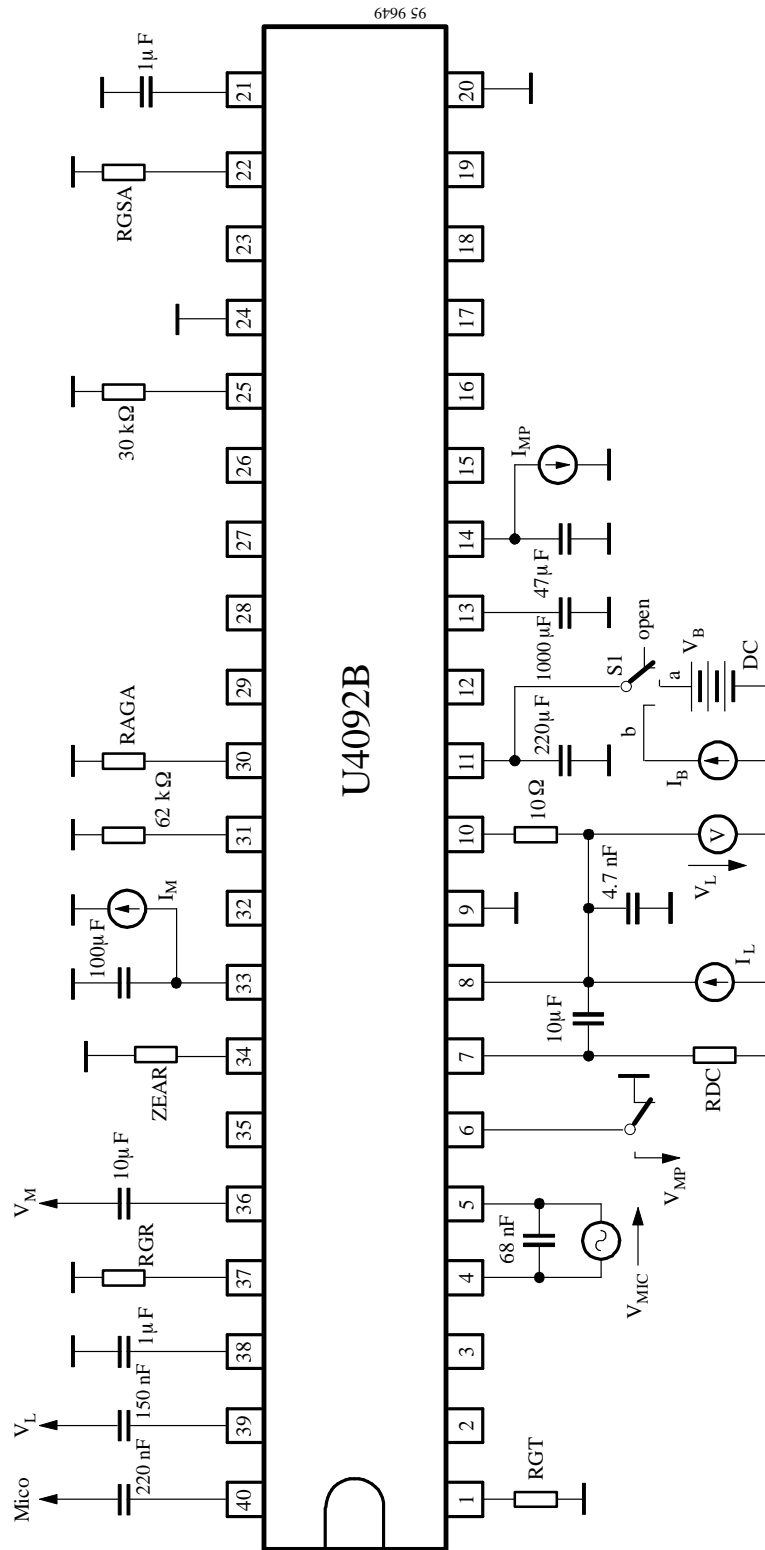

Figure 21 Basic test circuit



Line detection: S1a
 V_B (external supply): S1b
 open pins should be connected as shown in figure 21

Figure 22 DC characteristics, line detection

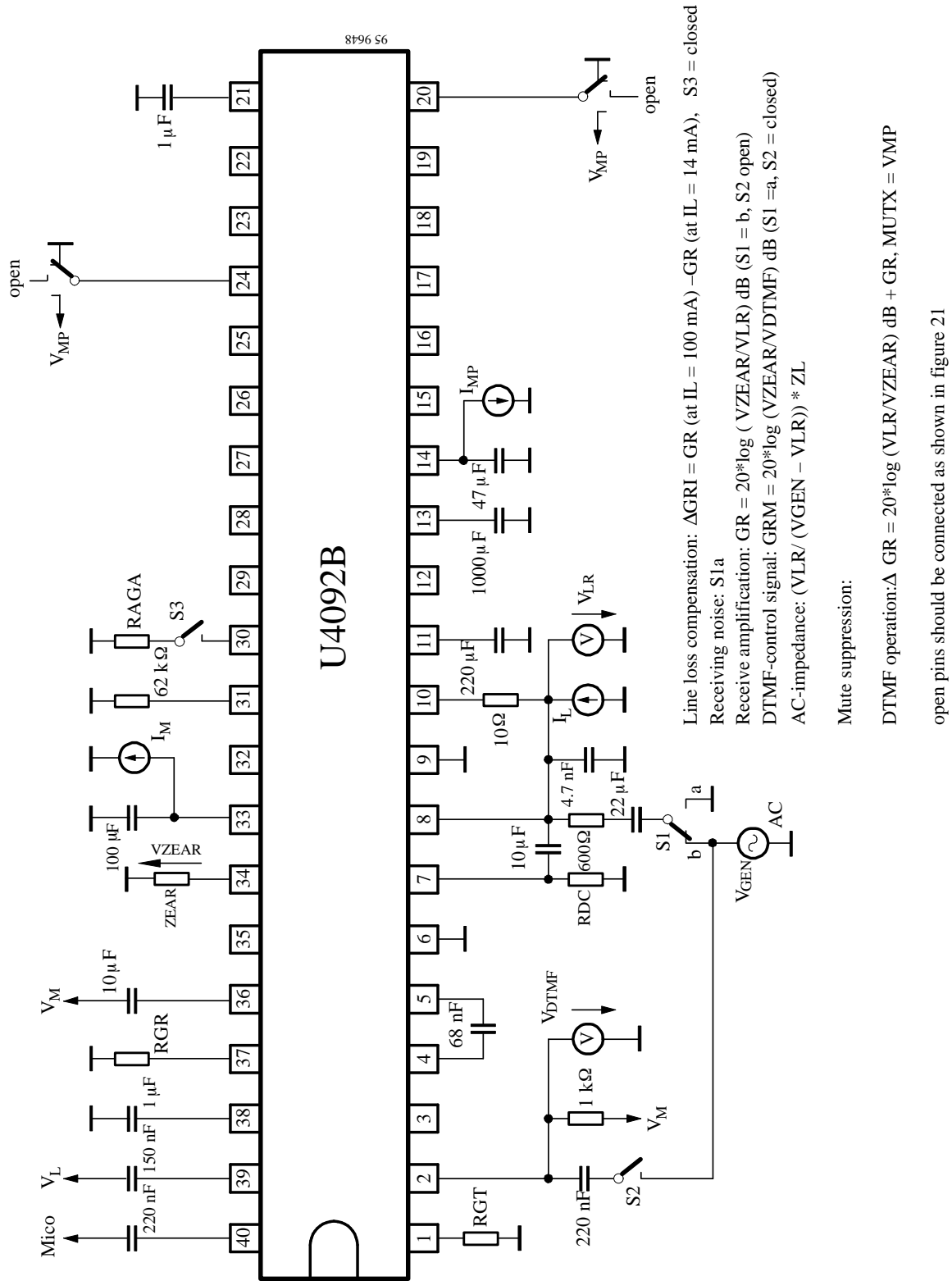

Figure 23 Receiving amplifier

Line loss compensation: $\Delta GRI = GR$ (at $I_L = 100 \text{ mA}$) -GR (at $I_L = 14 \text{ mA}$), $S3 = \text{closed}$
 Receiving noise: $S1a$
 Receive amplification: $GR = 20 \cdot \log (V_{ZEAR}/V_{LR}) \text{ dB}$ ($S1 = b$, $S2 \text{ open}$)
 DTMF-control signal: $GRM = 20 \cdot \log (V_{ZEAR}/V_{DTMF}) \text{ dB}$ ($S1 = a$, $S2 = \text{closed}$)
 AC-impedance: $(V_{LR}/(V_{GEN} - V_{LR})) \cdot Z_L$

Mute suppression:

DTMF operation: $\Delta GR = 20 \cdot \log (V_{LR}/V_{ZEAR}) \text{ dB} + GR$; $MUTX = V_{MP}$

open pins should be connected as shown in figure 21

U4092

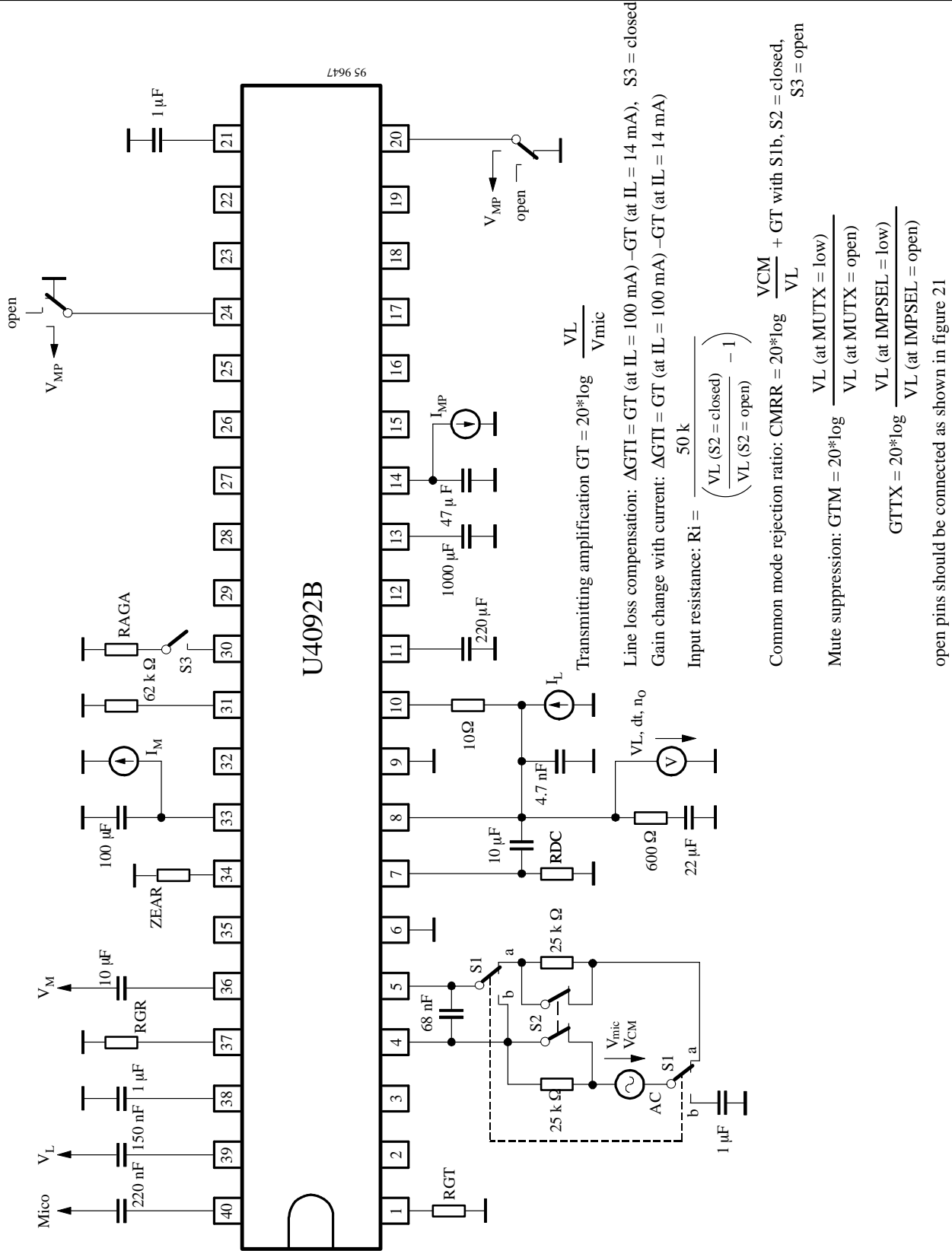

Figure 24 Transmission amplifier

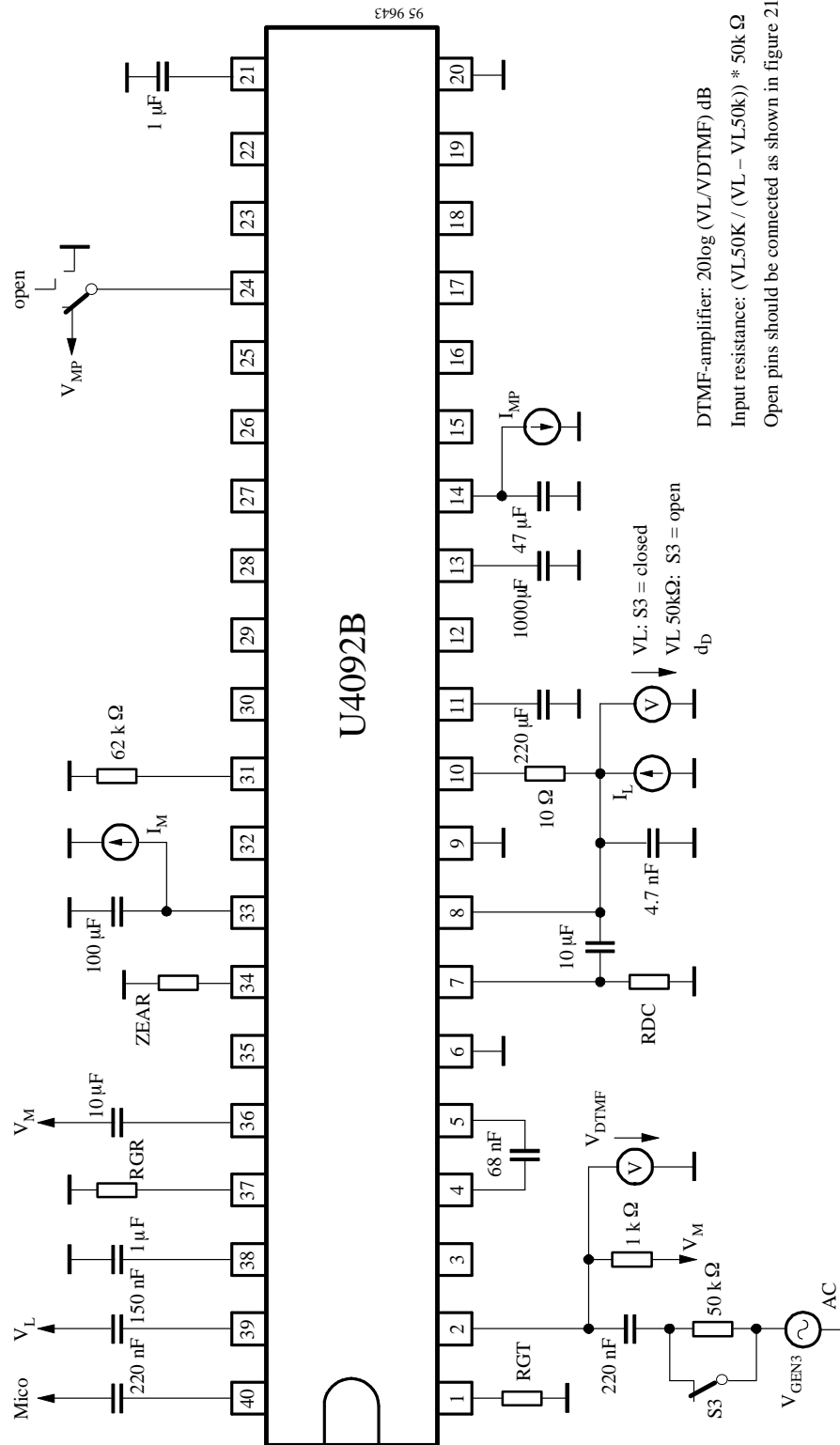

Figure 25 DTMF amplifier

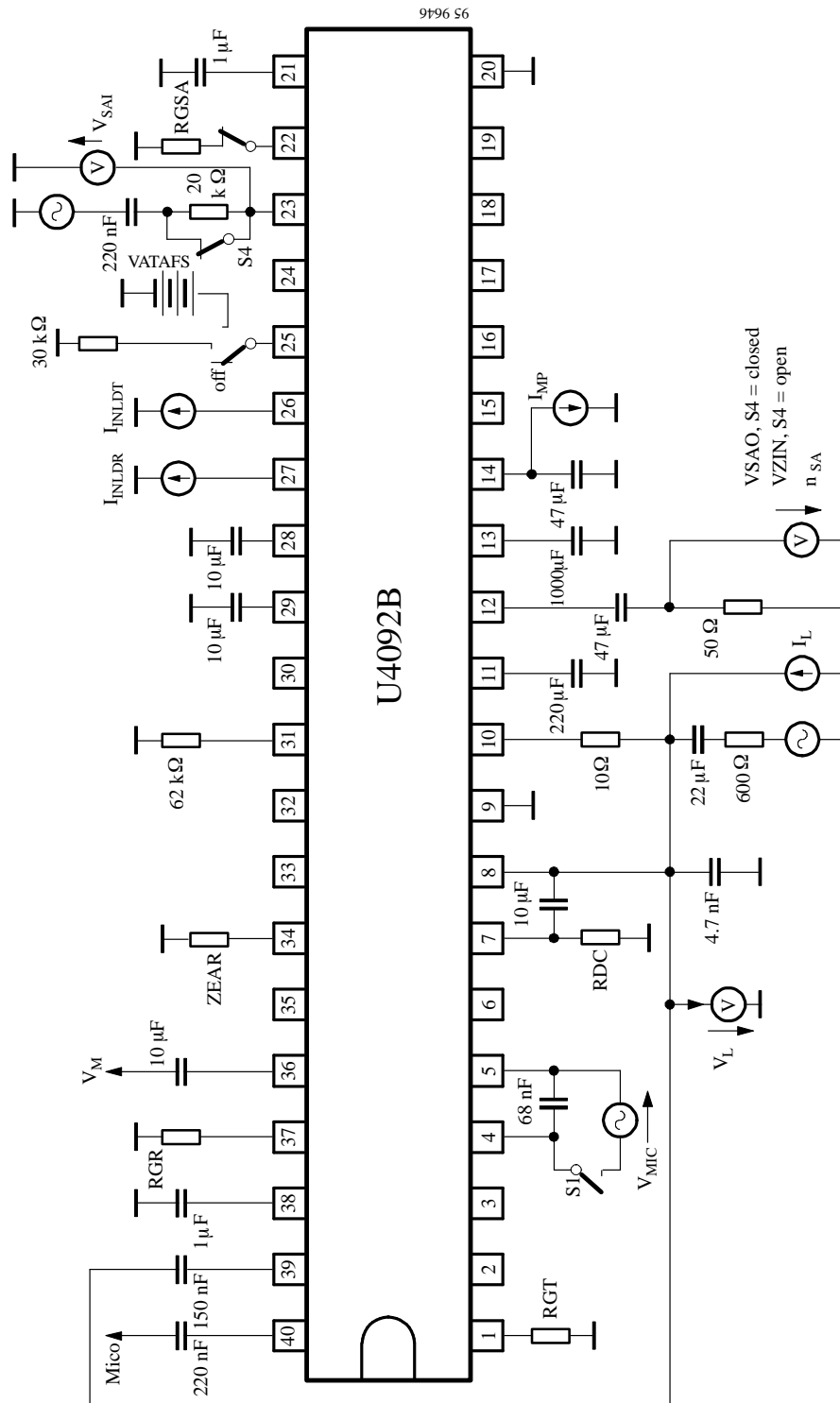

Figure 27 Speaker amplifier

Input impedance: $(V_{ZIN}/(V_{SAO} - V_{ZIN})) * R_{IN}$

Gain from SAI to SAO: $20 * \log (V_{SAO} / V_{SAI}) \text{ dB}$

$$\text{Output power: } P_{SA} = \frac{V_{SAO}^2}{R_{SAO}}$$

Attenuation of transmit gain: S1 = closed

Open pins should be connected as shown in figure 21

U4092

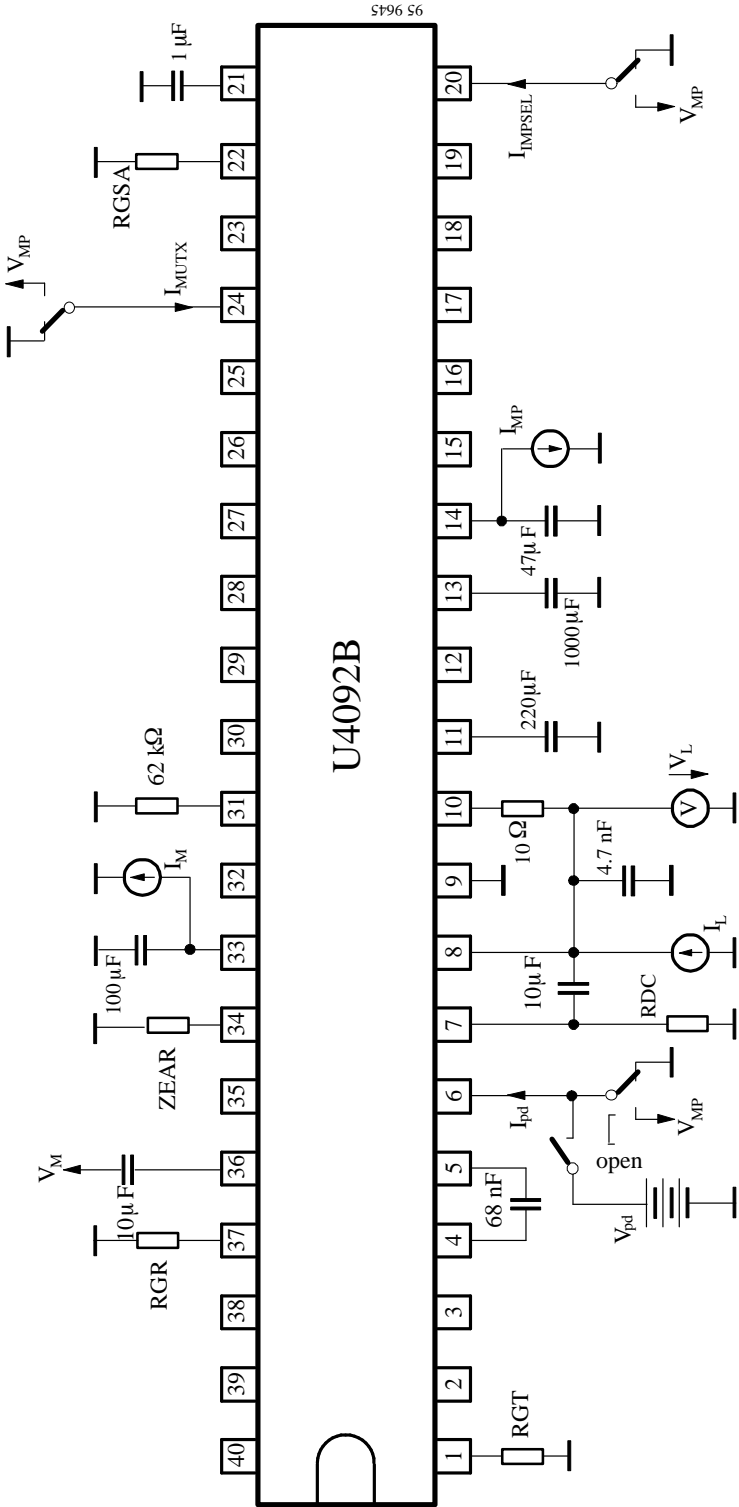

Figure 28 Input characteristic

Open pins should be connected as shown in figure 21

Ordering information

Type	Package
U4092B-SD	SDIP 40

Dimensions in mm

Package: SDIP 40

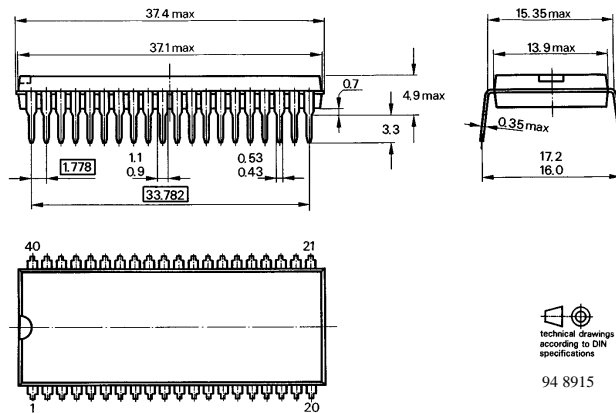

We reserve the right to make changes without further notice to improve technical design.

Parameters can vary in different applications. All operating parameters must be validated for each customer application by customer. Should Buyer use TEMIC products for any unintended or unauthorized application, Buyer shall indemnify TEMIC against all claims, costs, damages, and expenses, arising out of, directly or indirectly, any claim of personal damage, injury or death associated with such unintended or unauthorized use.

TEMIC TELEFUNKEN microelectronic GmbH, P.O.B. 3535, D-74025 Heilbronn, Germany
Telephone: 49 (0)7131 67 2831, Fax Number: 49 (0)7131 67 2412

OZONE DEPLETING SUBSTANCES POLICY STATEMENT

It is the policy of **TEMIC TELEFUNKEN microelectronic GmbH** to

1. Meet all present and future national and international statutory requirements and
2. Regularly and continuously improve the performance of our products, processes, distribution and operating systems with respect to their impact on the health and safety of our employees and the public, as well as their impact on the environment.

Of particular concern is the control or elimination of releases into the atmosphere of these substances which are known as ozone depleting substances (ODSs).

The Montreal Protocol (1987) and its London Amendments (1990) will severely restrict the use of ODSs and forbid their use within the next ten years. Various national and international initiatives are pressing for an earlier ban on these substances.

TEMIC TELEFUNKEN microelectronic GmbH semiconductor division has been able to use its policy of continuous improvements to eliminate the use of any ODSs listed in the following documents that all refer to the same substances:

- (1) Annex A, B and list of transitional substances of the Montreal Protocol and the London Amendments respectively
- (2) Class I and II ozone depleting substances in the Clean Air Act Amendments of 1990 by the Environmental Protection Agency (EPA) in the USA and
- (3) Council Decision 88/540/EEC and 91/690/EEC Annex A, B and C (transitional substances) respectively.

TEMIC can certify that our semiconductors are not manufactured with and do not contain ozone depleting substances.